

# SUSS MA8 Mask Aligner



## EQUIPMENT DATASHEET

---

### Tool Configuration :

Item List		Notes
Manufacturer:	Karl SUSS	
Model:	MA8 / BA8	
Wafer Size:	200mm	
Vintage:	2006	
Quantity:	1	
Tool Condition:	Used	
Volts / HZ/Ph:	200~230V,50/60Hz	
Power:	2.6kVA 1+N/2Phase	
I <sub>max</sub> :	AIC 1kA	
Other:	<ul style="list-style-type: none"><li>➤ Media Supply/[1 MPa=10 bar]</li><li>➤ Vac: -0.08MPa</li><li>➤ CDA(air): 0.6MPa</li><li>➤ N2: 0.3MPa</li></ul>	

# EQUIPMENT DATASHEET

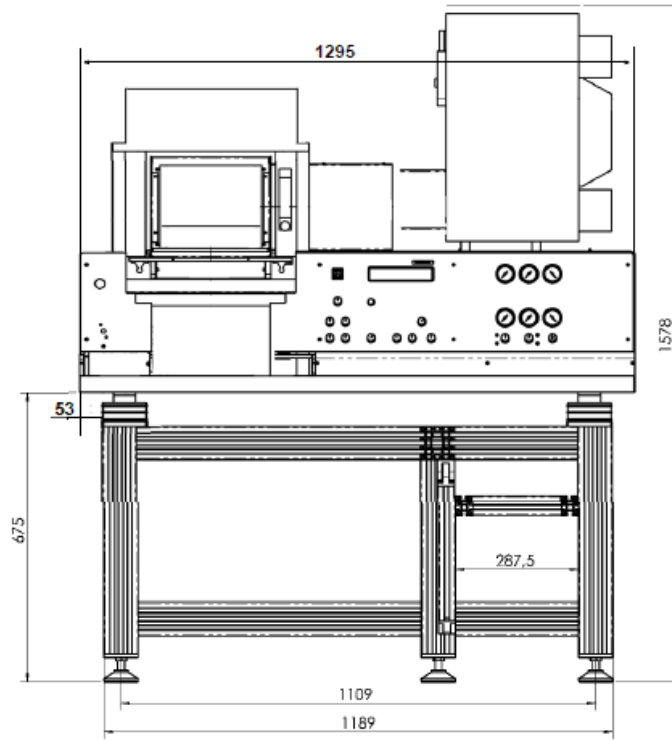

Front view

SIDE VIEW  
MA8

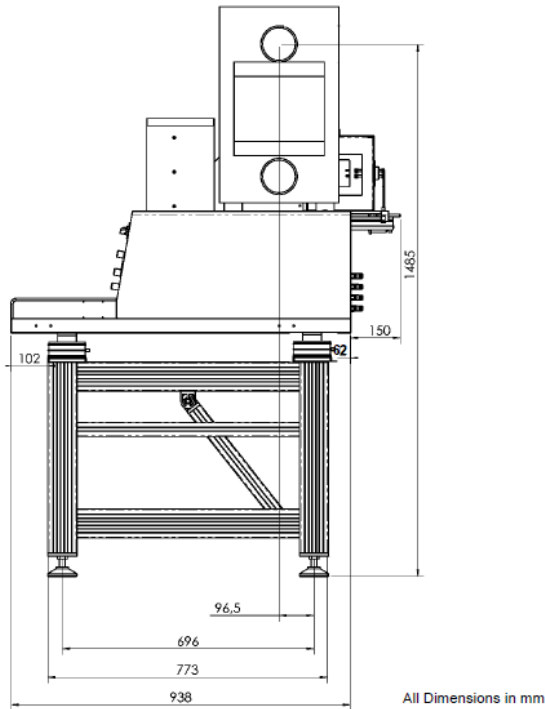

Side view

# EQUIPMENT DATASHEET

---

## INCLUDE:

1. Main Body
2. Stage Unit
3. Lamp House Unit
4. TSA Unit
5. BSIR Unit
6. Other Parts:
  - A. Light Power Meter

## PHOTO:



# EQUIPMENT DATASHEET

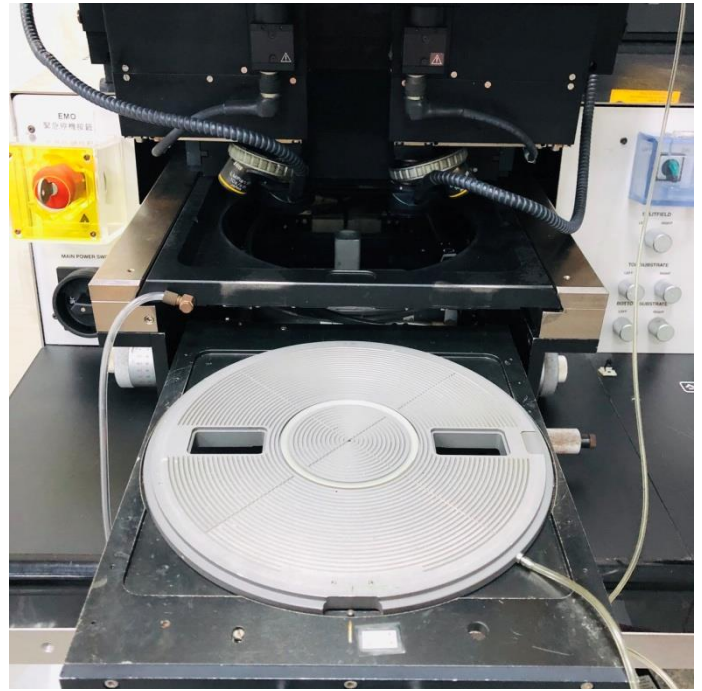

# EQUIPMENT DATASHEET

---

